

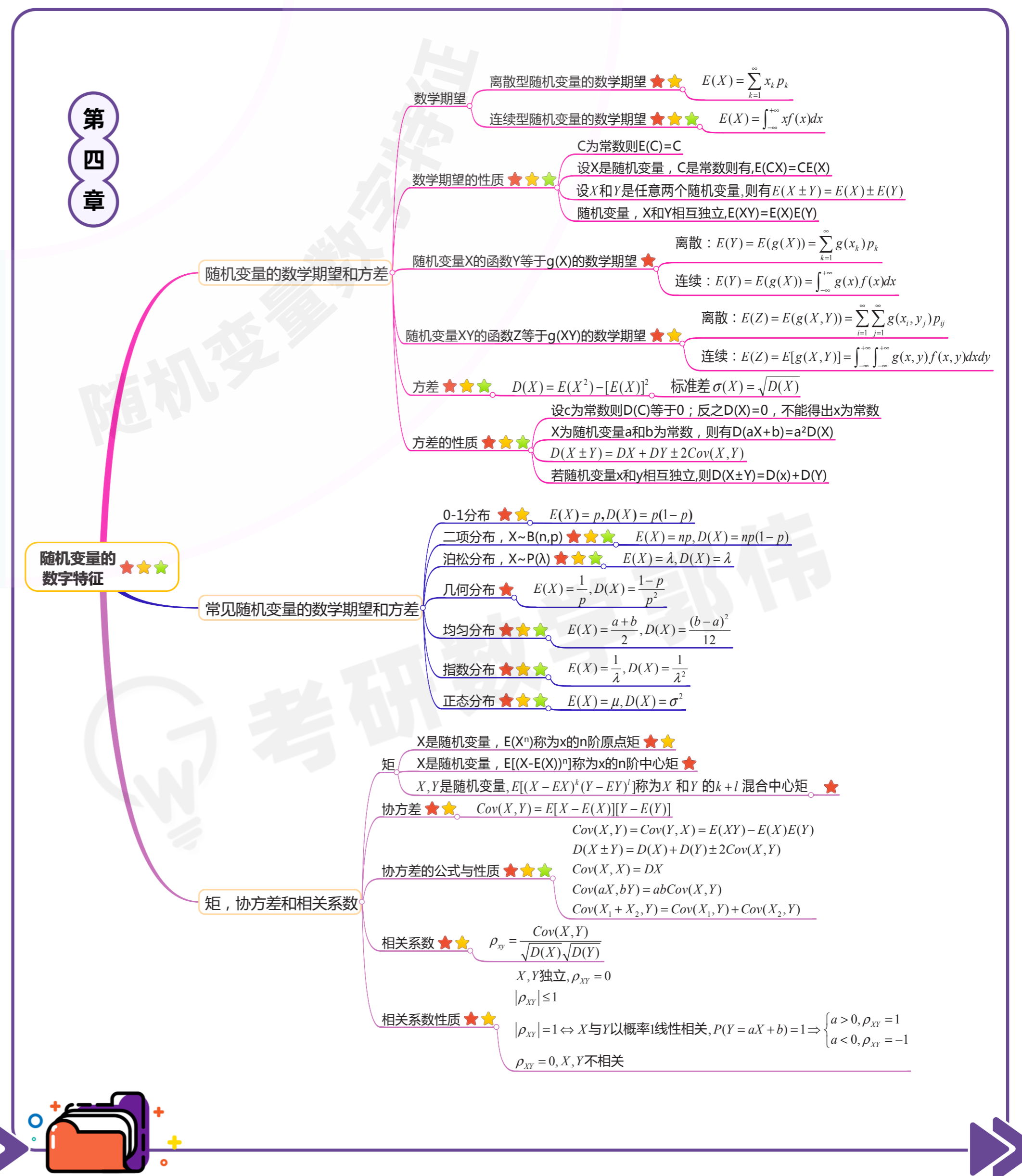

考研数学概率论与数理统计思维导图 (一)

★★★ 高频重要考点 ★★ 中频一般考点 ★ 低频考点

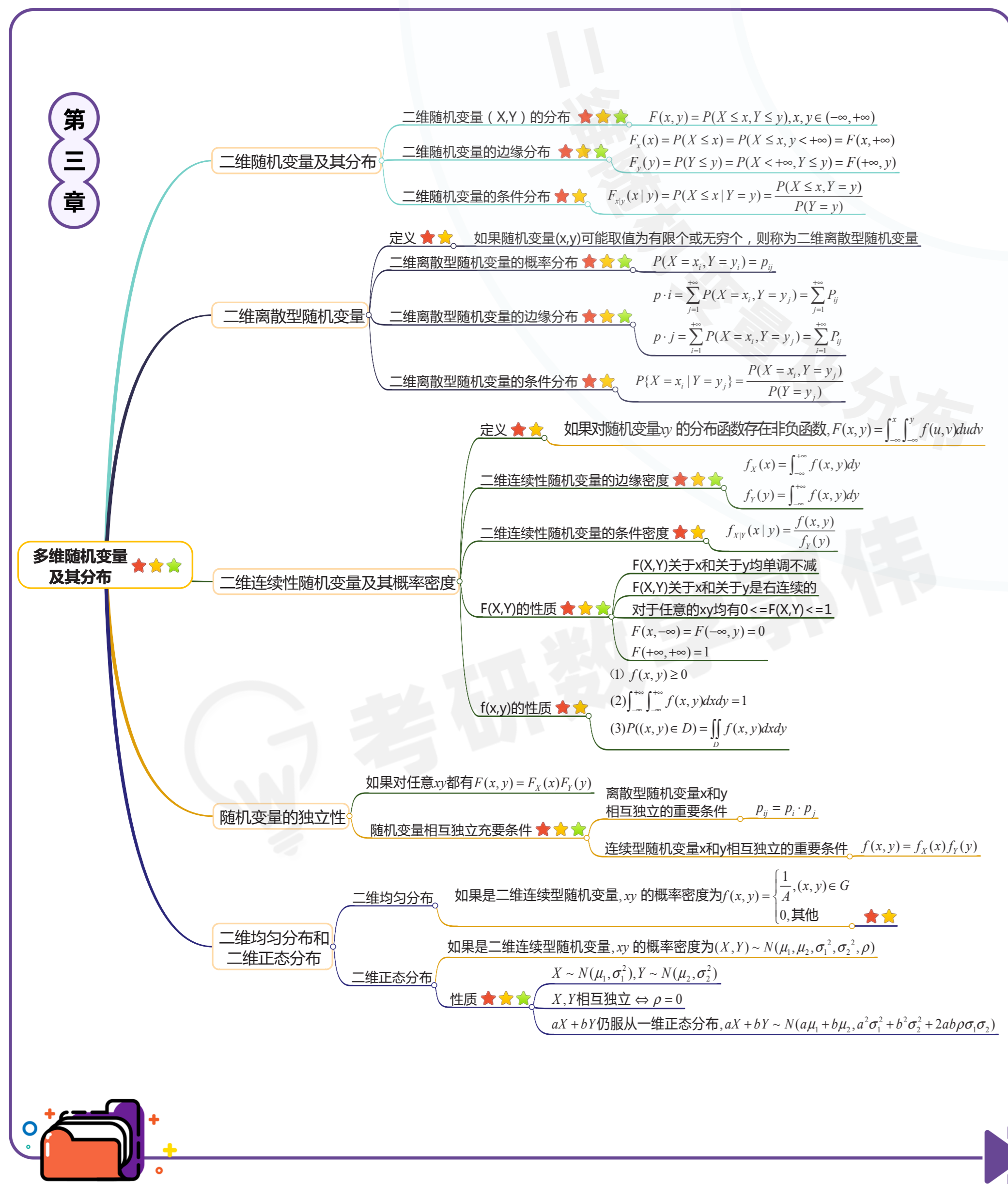

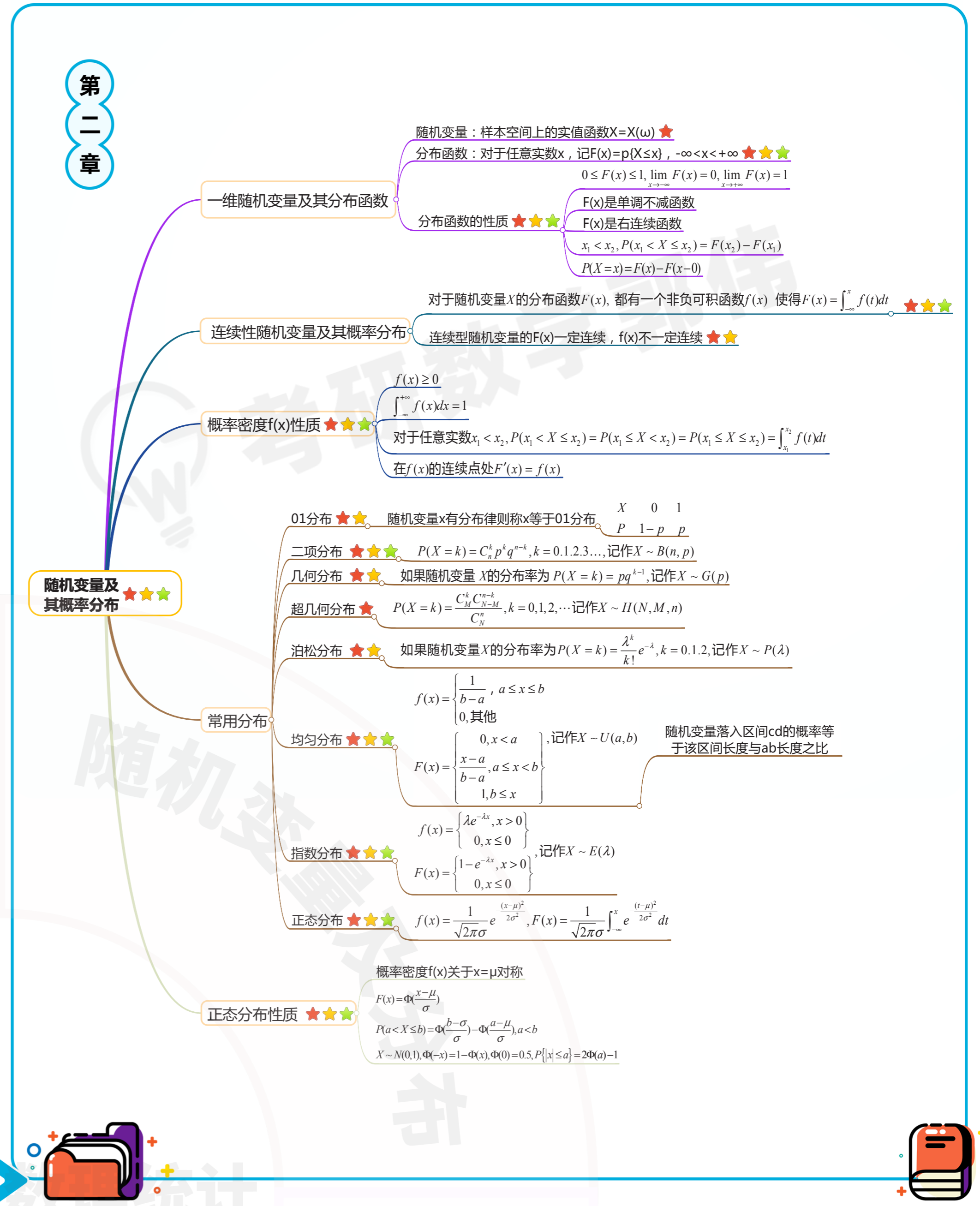
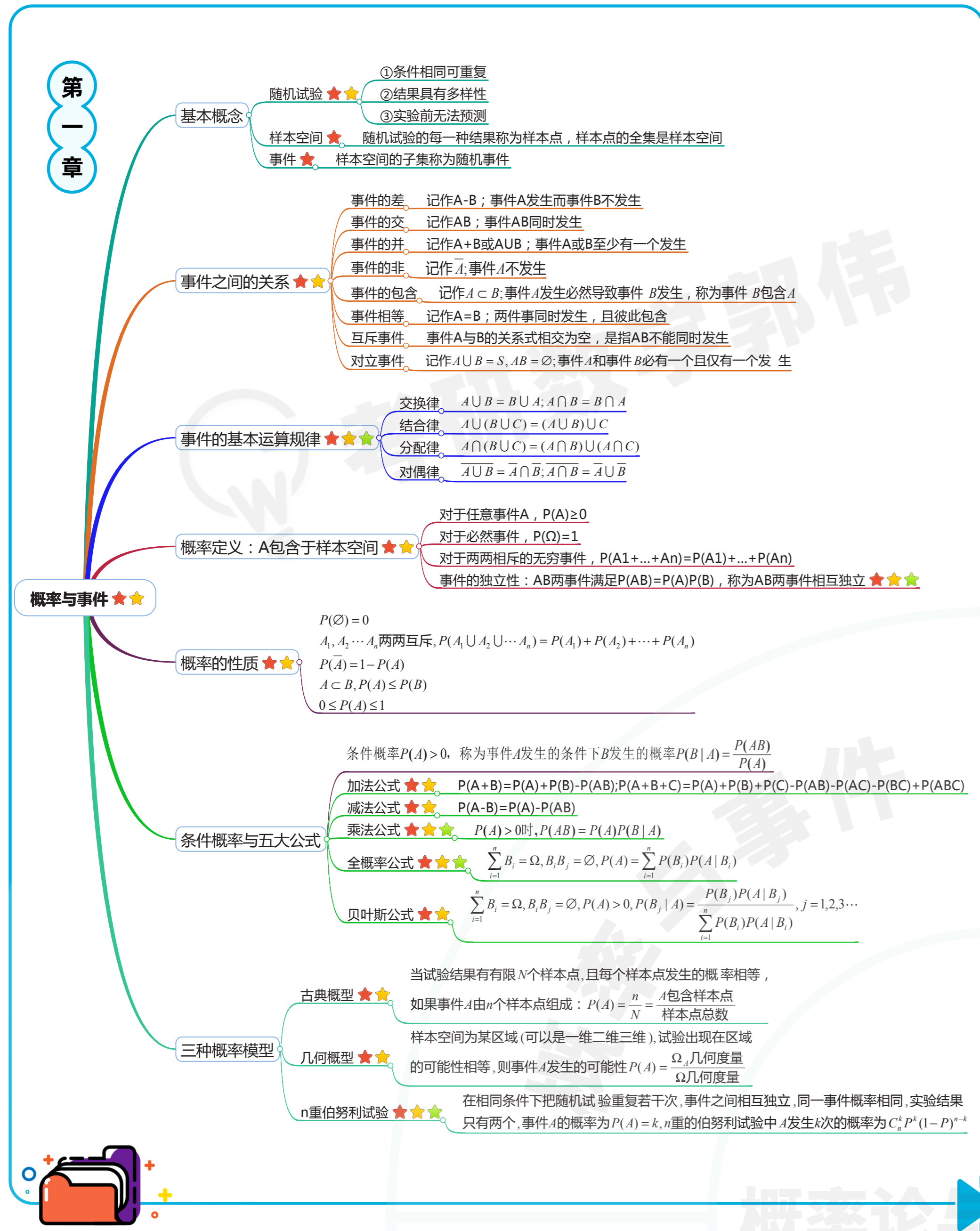

考研数学概率论与数理统计思维导图 (二)

★★★ 高频重要考点 ★★ 中频一般考点 ★ 低频考点

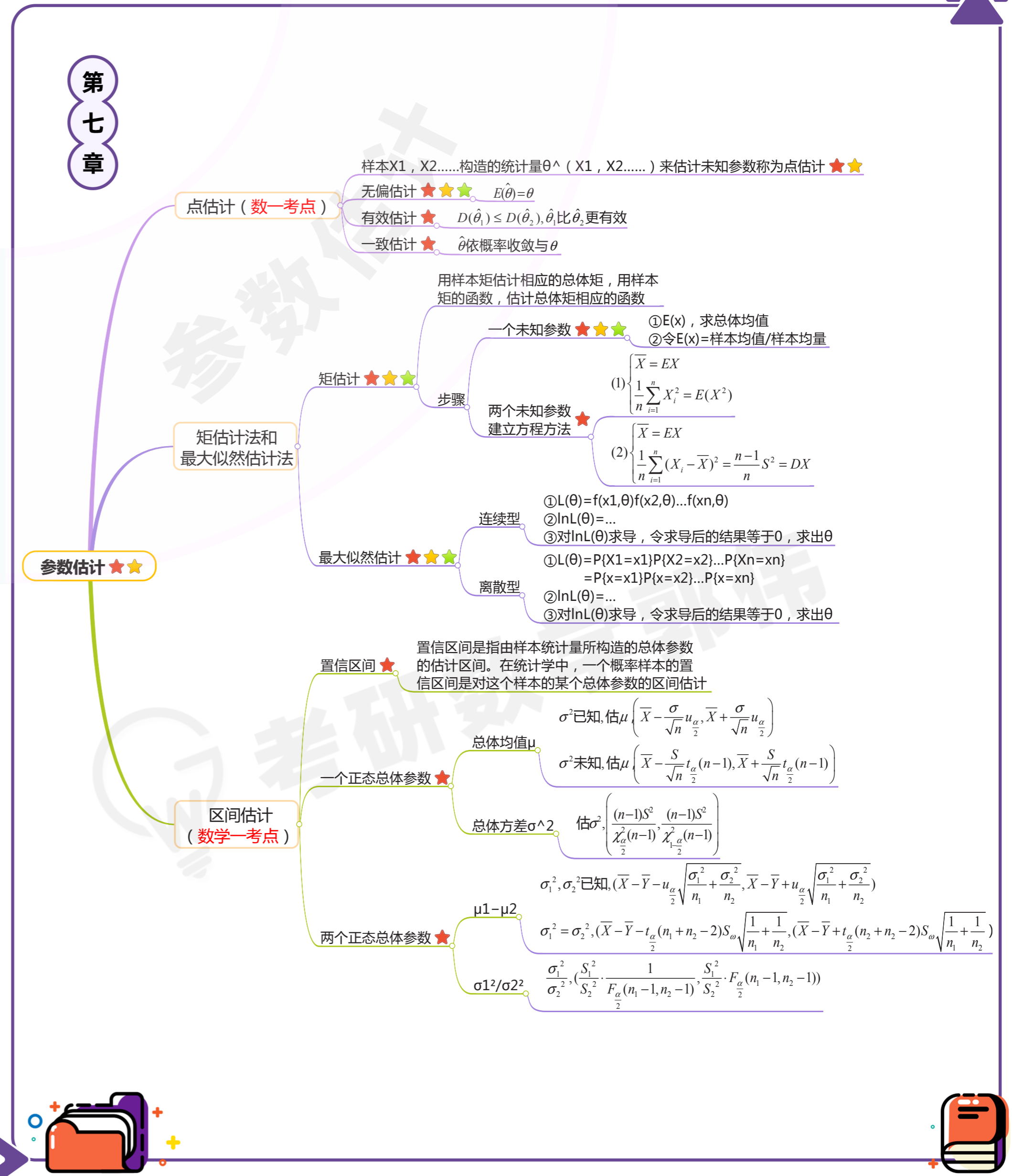
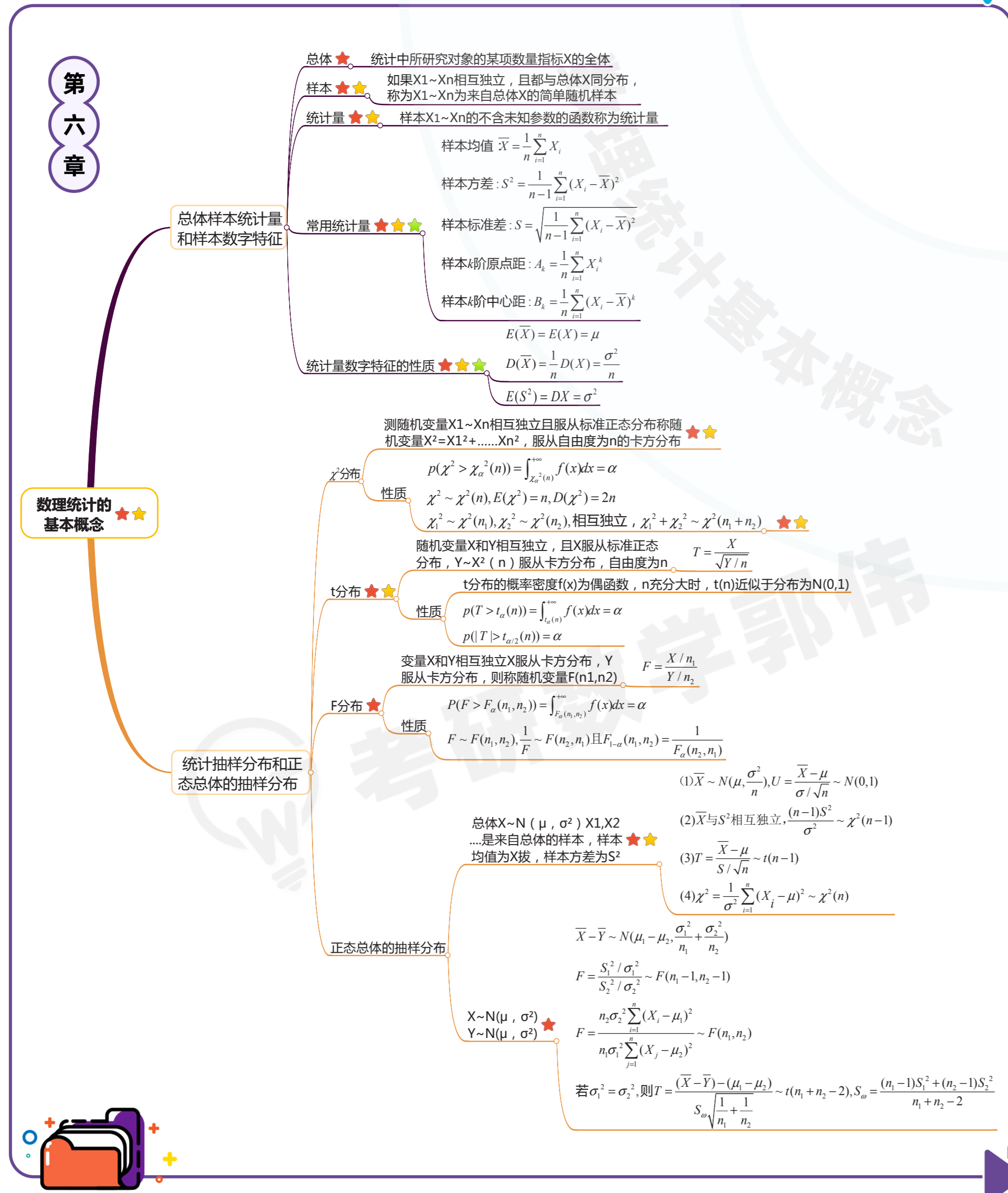
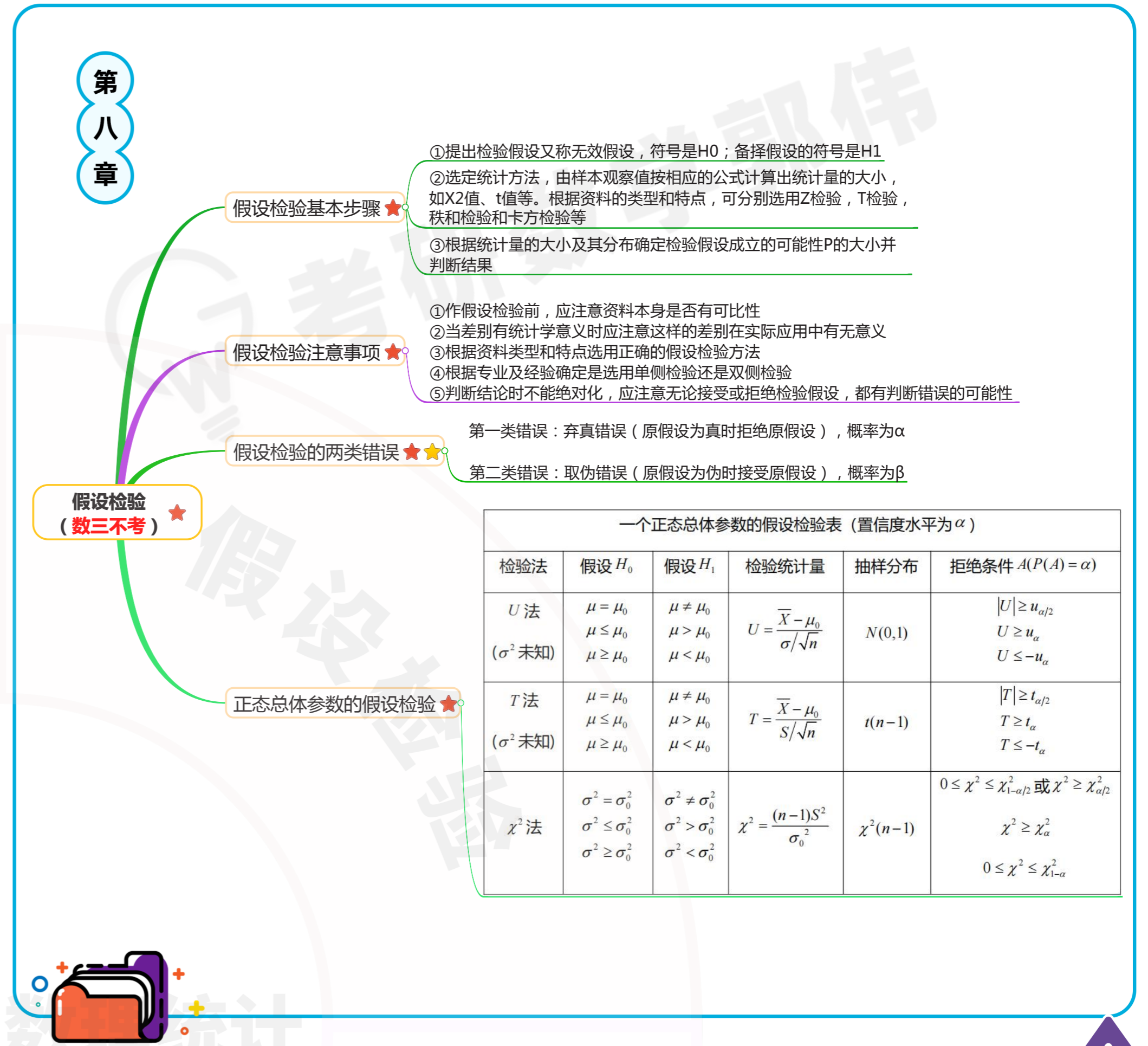
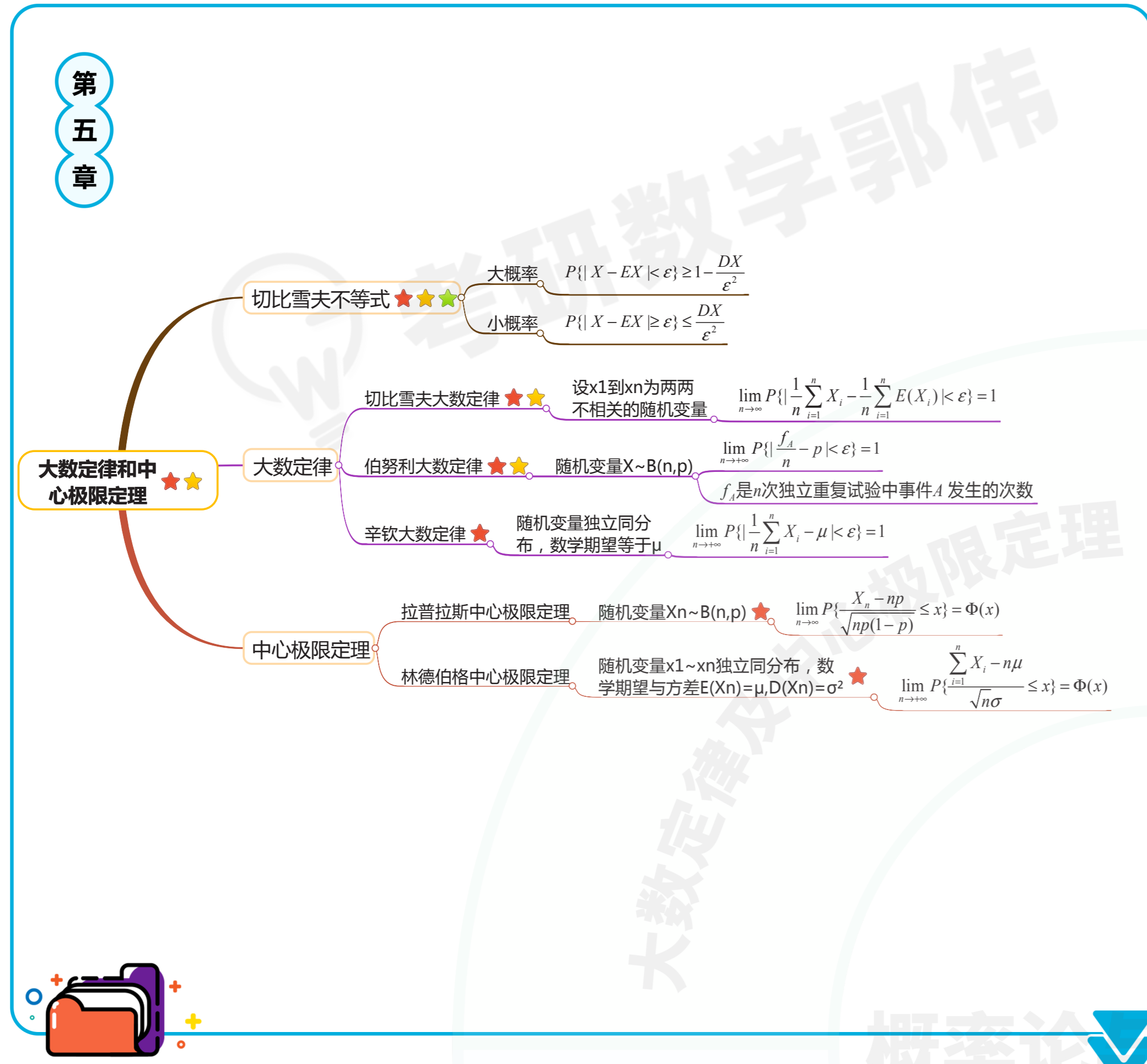

考研数学郭伟系列图书介绍



《夯实基础220题》: 受 2w+ 上岸学员好评推荐的基础过渡强化必刷习题集!

- ① 一题一考法, 串联新大纲;
- ② 题型解法总结全, 构建完整知识体系;
- ③ 搭配逐题精讲课, 快速基础救急!



《证明题解题思路大全》: 考研数学冲击 120+ 的必备解题手册!

- ① 内容新, 完美匹配新大纲;
- ② 题型全, 收录真题常考五大专题;
- ③ 解法细, 一题多解详尽分析;
- ④ 讲解透, 名师串讲破解迷津, 实现从“懂”到“会”的跨越!

